



DHYK-8822CE Information Sheet

Wi-Fi 802.11 ac/a/b/g/n 2x2 + Bluetooth
V5.0 combo M.2 2230 module, RTL8822CE



Overview:

DHYK-8822CE is an 802.11 ac/a/b/g/n dual band 2x2 Wi-Fi and Bluetooth V5.0 combo M.2 2230 module designed for devices which require small size and low power consumption. It's a highly integrated module that supports 2-stream 802.11ac Wave 2 with MU-MIMO (Multi-User Multiple-Input, Multiple-Output), Transmit Beamforming, and Bluetooth. With highly integrated technology, DHYK-8822CE provides high coverage and throughput performance suitable for high quality video and media applications at home and enterprises.

Feature:

❖ Wi-Fi Features:

- ◆ Supports 20/40MHz at 2.4GHz and supports 20/40/80MHz at 5GHz
- ◆ Operates at ISM frequency Band (2.4/5GHz)
- ◆ Wi-Fi compliant with 802.11ac 2x2 Wave 2 provides advanced features including MU-MIMO and Transmit Beamforming
- ◆ Two-stream spatial multiplexing up to 866.7Mbps data rate
- ◆ IEEE Standards Support, 802.11a, 802.11b, 802.11g, 802.11n, 802.11ac and 802.11i

❖ BT Features:

- ◆ Bluetooth supports V5.0, V4.2, V4.0 LE, V3.0+HS, V2.1+EDR, and it's backward compatible with V1.1, V1.2 and V2.0
- ◆ Bluetooth supports Class 1 (TX power maximum up to +6 dBm)
- ◆ Bluetooth transmission speed includes 1Mbps, 2Mbps and 3Mbps EDR operations
- ◆ Bluetooth V5.0 supports Low Energy 2M PHY
- ◆ Bluetooth supports Simple Pairing (SP), Enhanced Inquiry Response (EIR), SCATTERNET and PICONET

❖ Common Features:

- ◆ M.2 (NGFF) 2230-S3-A-E form factor
- ◆ Two IPEX MHF4 antenna connectors (2 for Wi-Fi and 1 for Bluetooth) for external antennas enable highest design flexibility
- ◆ Supports Windows 10, Android* and Linux* drivers (*. by project)

Specifications

❖ Wi-Fi Function:

Chipset	Realtek RTL8822CE
Tx/Rx	2T2R
Standard Conformance	IEEE 802.11a, 802.11b, 802.11g, 802.11n, 802.11ac
Bus Interface	PCI Express
Frequency Range	<ul style="list-style-type: none"> ❖ 802.11a/ac: 5.15~5.85 GHz ❖ 802.11bg: 2.412~2.484 GHz *Subject to local regulations
Operating Channels	<ul style="list-style-type: none"> ❖ 5GHz <ul style="list-style-type: none"> ◆ USA/Canada: 12 non-overlapping channels ◆ Europe: 19 non-overlapping channels ◆ Japan: 8 non-overlapping channels ❖ 2.4GHz <ul style="list-style-type: none"> ◆ USA/Canada: 11 (1-11) ◆ Europe: 13 (1-13) ◆ Japan: 14 (1-14)
Data Rate	<ul style="list-style-type: none"> ❖ 802.11a: 6, 9, 12, 18, 24, 36, 48, 54Mbps ❖ 802.11b: 1, 2, 5.5 and 11Mbps ❖ 802.11g: 6, 9, 12, 18, 24, 36, 48, 54Mbps ❖ 802.11n: <ul style="list-style-type: none"> ◆ 20MHz bandwidth (HT20): MCS 0 to 15 ◆ 40MHz bandwidth (HT40): MCS 0 to 15 ❖ 802.11ac:

- ◆ 20MHz bandwidth (HT20): MCS 0 to 8
- ◆ 40MHz bandwidth (HT40): MCS 0 to 9
- ◆ 80MHz bandwidth (HT80): MCS 0 to 9

Transmit Output Power
(power tolerance \pm 2dBm)

- ❖ 802.11a: 17dBm@54Mbps
- ❖ 802.11b: 18dBm@11Mbps
- ❖ 802.11g: 17dBm@54Mbps;
- ❖ 802.11n 5GHz/HT20: 16dBm@MCS7
- ❖ 802.11n 5GHz/HT40: 16dBm@MCS7
- ❖ 802.11n 2.4GHz/HT20: 16dBm@MCS7
- ❖ 802.11n 2.4GHz/HT40: 16dBm@MCS7
- ❖ 802.11ac 5GHz/HT80: 14dBm@MCS9

Receiver Sensitivity

- ❖ 802.11a: -68dBm@54Mbps
- ❖ 802.11b: -85dBm@11Mbps
- ❖ 802.11g: -88dBm@6Mbps; -74dBm@54Mbps
- ❖ 802.11n 5GHz/HT20: -85dBm@MCS0; -67dBm@MCS7
- ❖ 802.11n 5GHz/HT40: -82dBm@MCS0; -64dBm@MCS7
- ❖ 802.11n 2.4GHz/HT20: -88dBm@MCS0; -70dBm@MCS7
- ❖ 802.11n 2.4GHz/HT40: -85dBm@MCS0; -67dBm@MCS7
- ❖ 802.11ac 5GHz/HT20: -62dBm@MCS8
- ❖ 802.11ac 5GHz/HT40: -59dBm@MCS9
- ❖ 802.11ac 5GHz/HT80: -54dBm@MCS9

MAC Protocol

CSMA/CA with ACK

Modulation Techniques

- ❖ 802.11a: 64QAM, 16QAM, QPSK, BPSK
- ❖ 802.11b: CCK, DQPSK, DBPSK
- ❖ 802.11g: 64QAM, 16QAM, QPSK, BPSK
- ❖ 802.11n: 64QAM, 16QAM, QPSK, BPSK
- ❖ 802.11ac: 256QAM, 64QAM, 16QAM, QPSK, BPSK

Security	64&128-bit WEP, WPA, WPA-PSK, WPA2, WPA2-PSK, WPA3 personal SAE, WPS, IEEE 802.1X, IEEE 802.11i
----------	---

Network Architecture	Ad-hoc mode (Peer-to-Peer), Infrastructure mode
----------------------	---

❖ Bluetooth Function:

Main Chipset	Realtek RTL8822CE
--------------	-------------------

Standard Conformance	Bluetooth V5.0, V4.2, V4.0LE, V3.0+HS, V2.1+EDR,
----------------------	--

Data Rate	1 Mbps, 2Mbps and Up to 3Mbps
-----------	-------------------------------

Bus Interface	USB 2.0
---------------	---------

Frequency Range	2.402 – 2.480 GHz
-----------------	-------------------

Modulation Scheme	GFSK, $\pi/4$ -DQPSK and 8-DPSK
-------------------	---------------------------------

Transmit Output Power	$0 \leq \text{Output Power} \leq +6\text{dBm}$; Class I Device
-----------------------	---

Receiver Sensitivity	$< 0.1\%$ BER at -70dBm
----------------------	----------------------------------

❖ Common Function:

Form Factor	M.2 (NGFF) 2230-S3-A-E
-------------	------------------------

Operation Voltage	3.3V $\pm 5\%$ supply voltage
-------------------	-------------------------------

3.3V Ripple/Noise	300mVpp @ switching frequency $> 400\text{KHz}$
-------------------	---

Operation Systems Supported	Windows 10, Android* (4.4, 6.x, 7.0, 8.0 and 9.x), Linux* (kernel 2.6.24 ~ v5.x) (*. by project)
-----------------------------	--

Power Consumption (Average)	<ul style="list-style-type: none"> ❖ TX mode (VHT20, 11ac): 606Ma ❖ RX mode (VHT80, 11ac): 302mA
-----------------------------	--

	<ul style="list-style-type: none"> ❖ Non-Associated Idle: 8.3mA ❖ Radio Disabled: 8.3mA <p>*Remark: the maximum current consumption will be impacted by radiation environment and the driver mechanism.</p>
Antenna	two IPEX MHF4 antenna connectors (Main connector for Wi-Fi, Aux connector for Wi-Fi/BT)
Operating Temperature Range	0°C - +70°C (ambient)
Operating Relative Humidity	5 – 90% (non-condensing)
Storage Temperature Range	-40°C - +80°C
Storage Relative Humidity	5 – 95% (non-condensing)
Regulation Compliance	FCC, IC, CE, TELEC, and others (by request)
Environment-Friendly Compliance	RoHS, Halogen Free

Block Diagram:

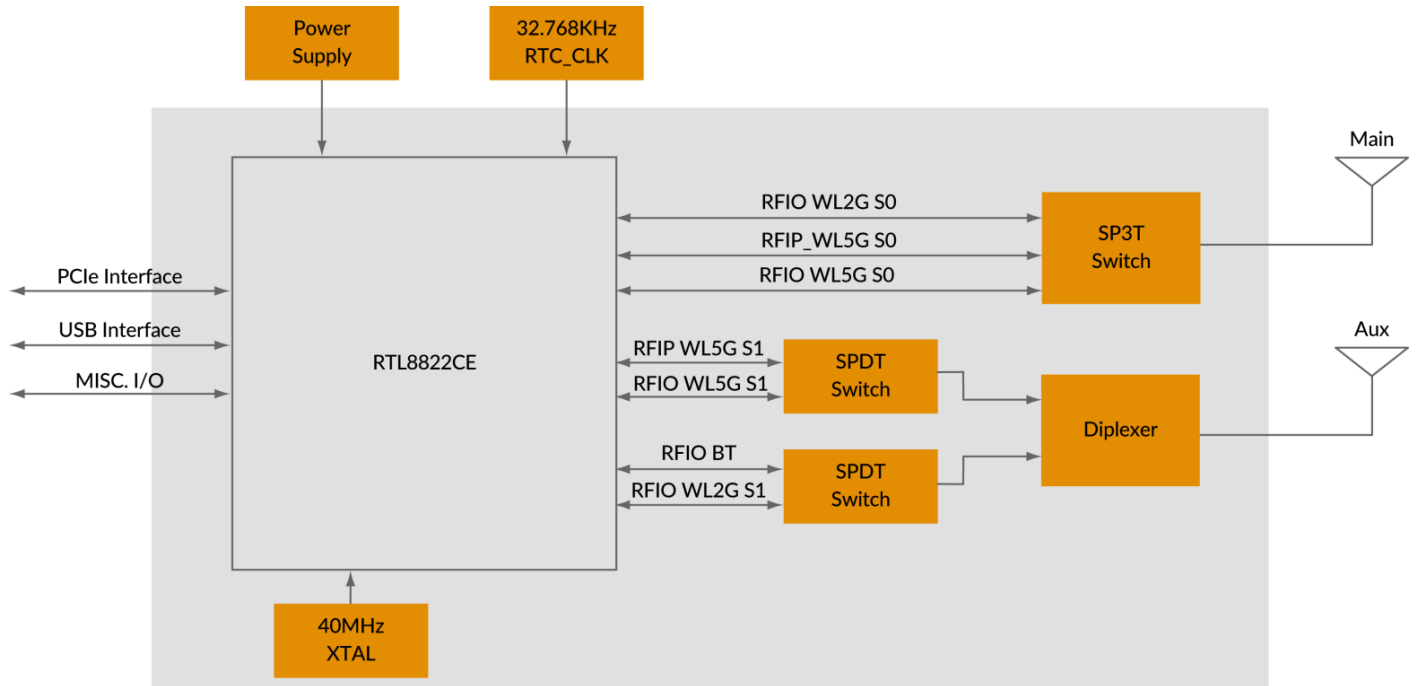

Mechanical Outline:

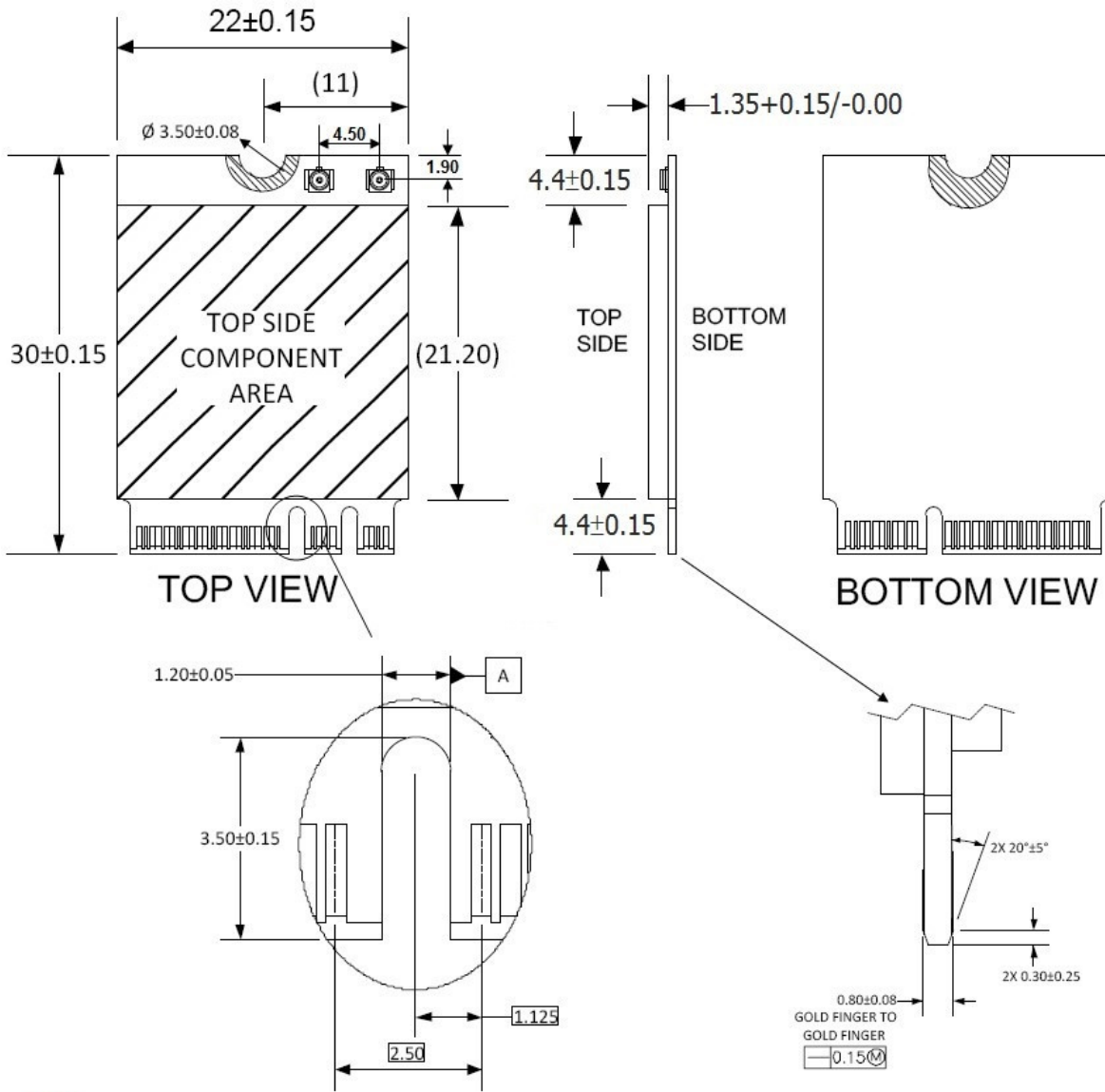

Unit: mm

MHF4 Connector Specification:

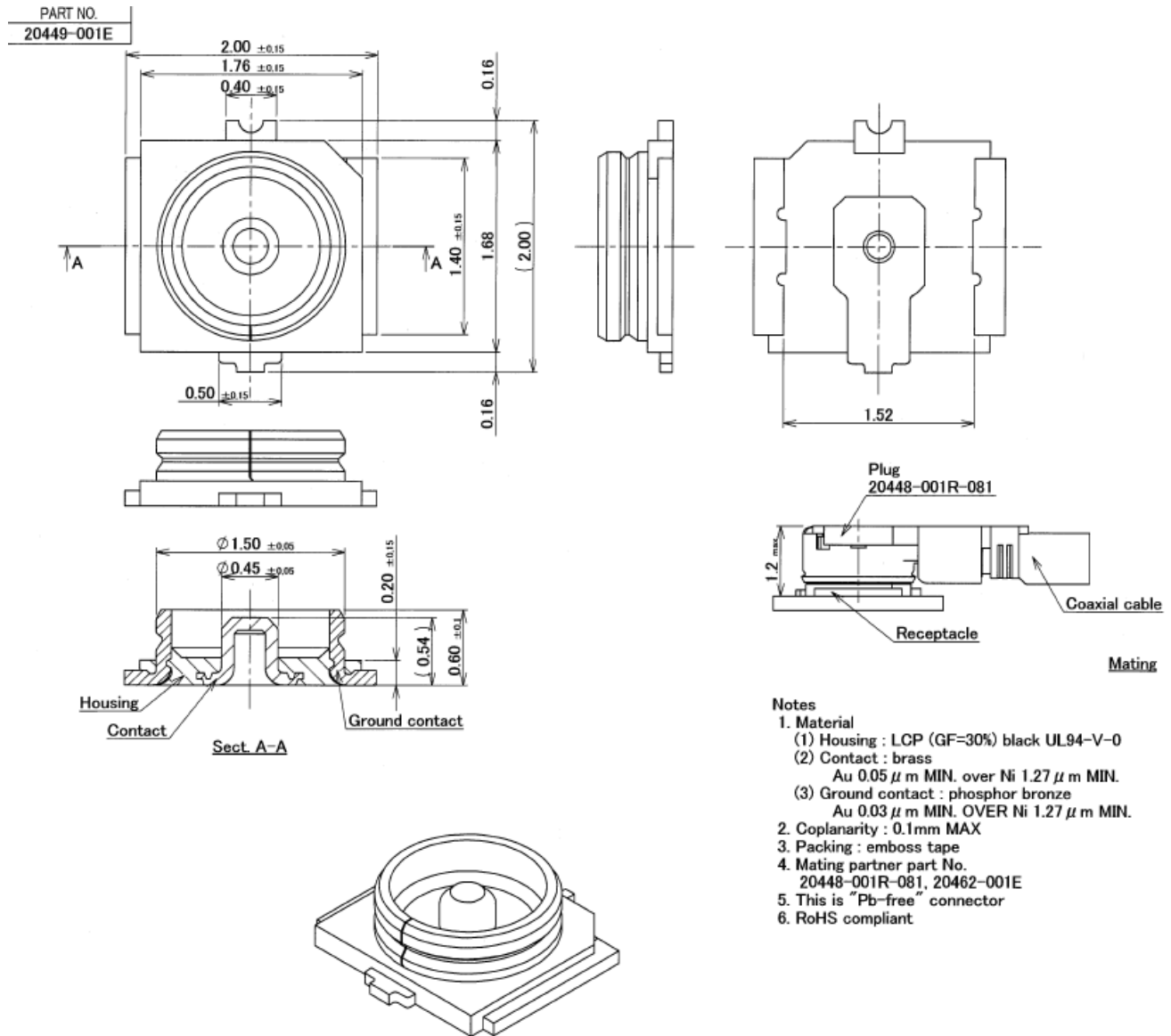

Notes

- Material
 - Housing : LCP (GF=30%) black UL94-V-0
 - Contact : brass
Au 0.05 μ m MIN. over Ni 1.27 μ m MIN.
 - Ground contact : phosphor bronze
Au 0.03 μ m MIN. OVER Ni 1.27 μ m MIN.
- Coplanarity : 0.1mm MAX
- Packing : emboss tape
- Mating partner part No.
20448-001R-081, 20462-001E
- This is "Pb-free" connector
- RoHS compliant

Pin Assignment: (Module Key A-E)

Pin	Description	Status	Pin	Description	Status
1	GND	YES	2	3.3V	YES
3	USB_D+	YES	4	3.3V	YES
5	USB_D-	YES	6	LED_WLAN#	YES
7	GND	YES	8	NOTCH	NC
9	NOTCH	NC	10	NOTCH	NC
11	NOTCH	NC	12	NOTCH	NC
13	NOTCH	NC	14	NOTCH	NC
15	NOTCH	NC	16	LED_BT#	YES
17	NC	NC	18	GND	YES
19	NC	NC	20	USB_WAKE	NC
21	NC	NC	22	UART_TX	NC
23	NC	NC	24	NOTCH	NC
25	NOTCH	NC	26	NOTCH	NC
27	NOTCH	NC	28	NOTCH	NC
29	NOTCH	NC	30	NOTCH	NC
31	NOTCH	NC	32	UART_RX	NC
33	GND	YES	34	UART_RTS	NC
35	PERp0	YES	36	UART_CTS	NC
37	PERn0	YES	38	BT_WAKE	NC
39	GND	YES	40	RESERVED	NC
41	PETp0	YES	42	RESERVED	NC
43	PETn0	YES	44	COEX3	NC
45	GND	YES	46	COEX2	NC
47	REFCLK+	YES	48	COEX1	NC
49	REFCLK-	YES	50	SUSCLK(32kHz)	YES
51	GND	YES	52	PERST#	YES
53	CLKREQ#	YES	54	BT_DISABLE#	YES
55	PEWAKE#	YES	56	WL_DISABLE#	YES
57	GND	YES	58	I2C DATA	NC
59	RESERVED	NC	60	I2C CLK	NC
61	RESERVED	NC	62	ALERT#	NC
63	GND	YES	64	RESERVED	NC
65	RESERVED	NC	66	RESERVED	NC

67	RESERVED	NC	68	RESERVED	NC
69	GND	YES	70	RESERVED	NC
71	RESERVED	NC	72	3.3V	YES
73	RESERVED	NC	74	3.3V	YES
75	GND	YES			

Interface Timing Specification

PCIe Bus during Power On Sequence

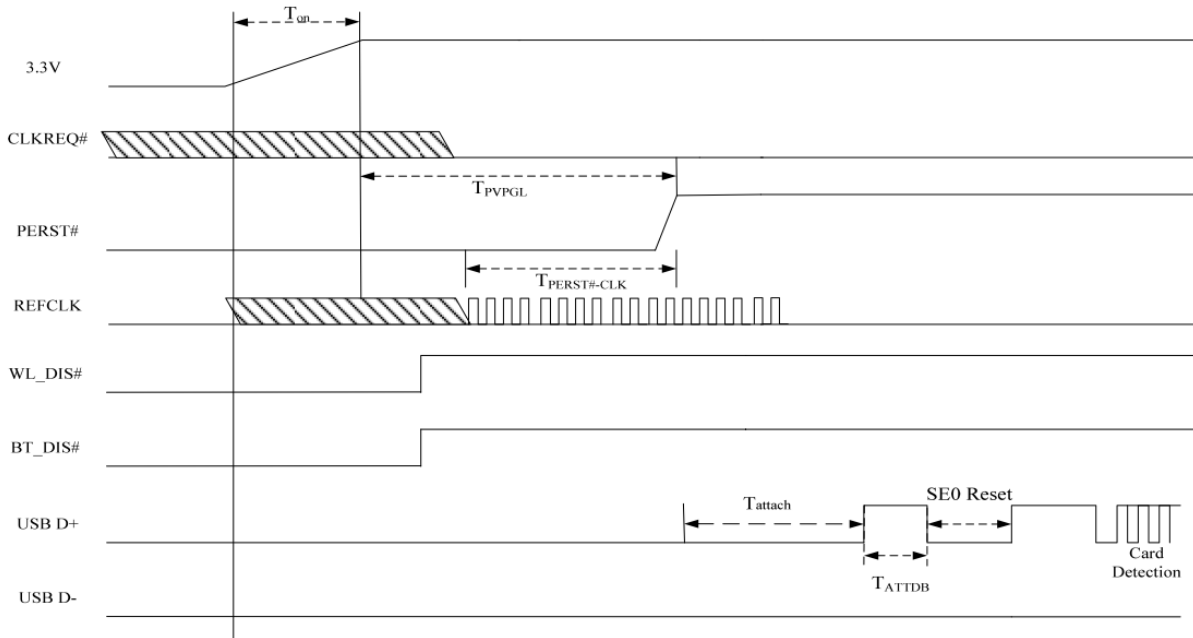

T_{on} : The main power ramp up duration

$T_{PV PGL}$: Power valid to PERST# input inactive

$T_{PERST\#-CLK}$: Reference clock stable before PERST# inactive

T_{attach} : The interval to turn on BT after PERST# de-asserted

T_{ATTDB} : the debounce interval with a minimal duration of 100ms that provided by the USB system Software

$T_{SE0 Reset}$: USB host send SE0 Reset duration

Table 1. The typical timing ranges

Symbol	Unit	Min	Typical	Max
T _{on}	ms	0.5	1.5	
T _{PVPG}	ms	Implementation Specific; recommended 50ms		--
T _{PERST#-CLK}	us	100	--	--
T _{attach}	ms	0.5	2	5
T _{ATTDB}	ms	100	--	--
T _{SE0 Reset}	ms	10	--	--

PCIe PERST# Timing Sequence (if need at least twice)

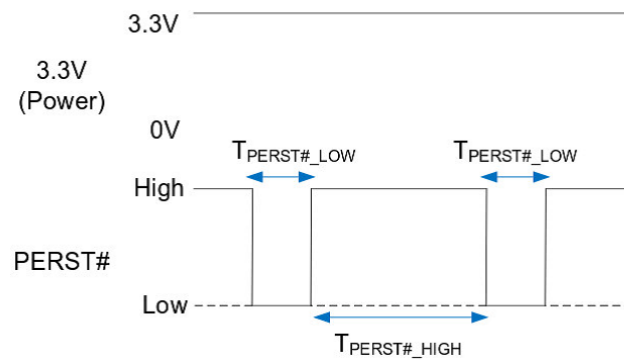

	Min	Typical	Max	Unit	Description
T _{PERST#_LOW}	6	10	X	ms	PERST# low duration
T _{PERST#_HIGH}	400	500	X	ms	PERST# high duration

Power Off Sequence

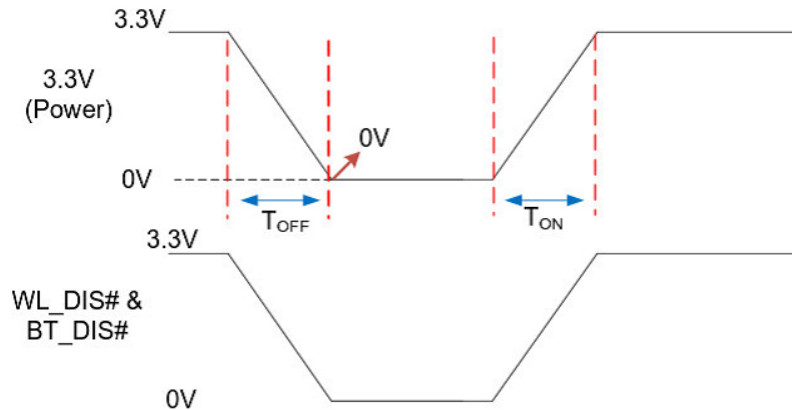

Symbol	Min	Typical	Max	Unit	Description
T_{OFF}	5	--	--	ms	Measure point start on 100% Measure point end on 0% (must be 0V)
T_{ON}	0.5	1.5	5	ms	Measure point start on 0% (must be 0V) Measure point end on 100%

Note: If BT_DIS# can't connect to the same power source with 3.3V, it need to be de-asserted before PERST# with 100ms in power on sequence.

BT_DIS Timing Sequence

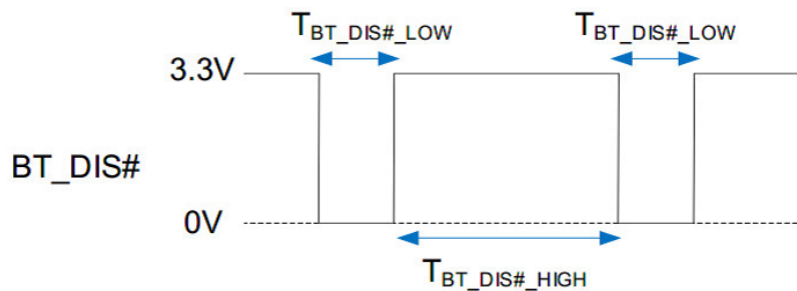

	Min	Typical	Max	Unit	Description
BT_DIS#_LOW	200	--	--	ms	BT_DIS# low duration
BT_DIS#_HIGH	500	--	--	ms	BT_DIS# high duration

Ordering Information:

DHYK-8822CE 802.11 ac/a/b/g/n 2x2 wifi and Bluetooth v5.0 combo M.2 2230 module, RTL8822CE

- ❖ Wireless radio modules are ESD sensitive, especially the components such as RF switch and the power amplifier. To avoid damage by electrostatic discharge, the following installation procedure is recommended:
 - ◆ Touch your hands and the bag or tray containing the radio module to a ground point on the host board (for example one of the mounting holes).
 - ◆ Install the radio module in the corresponding socket of host board.
 - ◆ Install the pigtail cable in the cutout of the enclosure. This will ground the pigtail to the enclosure.
 - ◆ Touch the antenna connector of the pigtail to the mounting hole (discharge), then plug onto the radio module.
 - ◆ Use external lightning protection for outdoor applications.
- ❖ Make sure all antennas are being connected with the radio module (don't leave antenna connector open) before powering on the host device.